

• **Spacious washing chamber :**

W. 630 x D. 630 x h. 850 mm > for the 63 series  
W. 830 x D. 830 x h. 850 mm > for the 87 series  
with easy access for large equipment.

- Sliding (C) or half sliding and half open-front (PA) front door.
- **Power and large capacity**, washes silently and instantly sheets, boxes, trays, mould, grilles, kitchen utensils, plastic containers, crates, etc.
- **Low space requirement**: for an easy installation.
- **Washing and rinsing system** with upper and lower rotating arms for astonishing results.
- **Quick cycles** : absorbing up to 15 baskets per hour.
- **Sense of savings**: reduces the consumption of energy, water and washing products.
- **Programmable**: to easily modify and modulate the cycles.

**ULTRA LARGE CAPACITY,  
POWERFUL AND RELIABLE,  
they meet all your professional  
requirements**



► **OPERATION**

- **Automatic cycle:**

**Wash** : modular from 0 to 10 mn,

**Drain** : modular from 5 to 50 sec,

**Rinse** : modular from 5 to 50 sec,

**Drain** : modular from 2 to 20 sec.

- **Pressure setting** : 1 front hand lever.

- **Capacity per cycle** :

**C63 & PA63** : 8 Gastro Norm containers GN 2/1 or 16

Gastro Norm containers GN 1/1 or 9 pastry sheets 600 x 800.

**C87 & PA87** : 16 Gastro Norm containers GN 2/1 or 32

Gastro Norm containers GN 1/1 or 18 pastry sheets 600 x 800.

► **DESIGN**

Stainless steel 18/10 (AISI 304).

Powerful washing pump.

Adjustable base.

Front door half sliding and half open-front - **PA63 &**

**PA87**- the half open-front part is used as a loading table  
Sliding door: **C63 & C87**.

Control box outside the handling area.

**Design and manufacture  
of machines tailored  
to a specific washing process.**

| MODELS                               | C63                            | PA63                           | C87                             | PA87                           |
|--------------------------------------|--------------------------------|--------------------------------|---------------------------------|--------------------------------|
| <b>Output/Basket/Hour</b>            | <b>15</b>                      | <b>15</b>                      | <b>15</b>                       | <b>15</b>                      |
| Washing bath heating power           | 3 kW                           | 3 kW                           | 6 kW                            | 6 kW                           |
| Rinse superheater power              | 6 kW                           | 6 kW                           | 6 kW                            | 6 kW                           |
| Washing pump power                   | 2,2 kW (3 cv)                  | 2,2 kW (3 cv)                  | 5,5 kW (7,5 cv)                 | 5,5 kW (7,5 cv)                |
| Maximum washing temperature          | 60°C                           | 60°C                           | 60°C                            | 60°C                           |
| Maximum rinsing temperature          | 90°C                           | 90°C                           | 90°C                            | 90°C                           |
| <b>Maximum power consumption</b>     | <b>12 kW</b>                   | <b>12 kW</b>                   | <b>18 kW</b>                    | <b>18 kW</b>                   |
| <b>Water consumption per cycle</b>   | <b>3,5 L</b>                   | <b>3,5 L</b>                   | <b>5 - 6 L</b>                  | <b>5 - 6 L</b>                 |
| <b>Water quantity for filling</b>    | <b>75 L</b>                    | <b>75 L</b>                    | <b>100 L</b>                    | <b>100 L</b>                   |
| <b>Washing surface (mm)</b>          | <b>630 w x 630 d</b>           | <b>630 w x 630 d</b>           | <b>830 w x 830 d</b>            | <b>830 w x 830 d</b>           |
| <b>Clearance height (mm)</b>         | <b>850</b>                     | <b>850</b>                     | <b>850</b>                      | <b>850</b>                     |
| Type of front door opening           | sliding                        | half open-front half sliding   | lift-up                         | half sliding half lift-up      |
| <b>Open space requirement (mm)</b>   | <b>821 w x 1085 d x 2740 h</b> | <b>770 w x 1350 d x 2212 h</b> | <b>1021 w x 1240 d x 2740 h</b> | <b>970 w x 1511 d x 2212 h</b> |
| <b>Closed space requirement (mm)</b> | <b>821 w x 1085 d x 2083 h</b> | <b>770 w x 914 d x 2083 h</b>  | <b>1021 w x 1240 d x 2083 h</b> | <b>970 w x 1069 d x 2083 h</b> |
| <b>Net weight</b>                    | <b>280 kg</b>                  | <b>280 kg</b>                  | <b>320 kg</b>                   | <b>320 kg</b>                  |

### ► SUPPLY

**Electricity:** 400 V three-phase + ground in 50 Hz.  
**Water :** 3/4 in. female- pressure required between 2.5 and 3.5 bars maximum.

### ► EQUIPMENT

Dosing pump for washing products.  
**C63 & PA63 :** 1 basket stainless steel 630 x 630 mm.  
 2 stainless steel grilles: to 630 x 630 mm.  
 1 insert 600 x 300 x 200 H. mm.  
**C87 & PA87 :** 2 half stainless steel baskets  
 415 x 830 mm.  
 2 stainless steel grilles: to 830 x 830 mm.  
 2 inserts: 800 x 300 x 200 H. mm.

### ► OPTIONS

1/2 additional baskets  
 Rinse booster pumps in case of network water pressure below 2.5 bars (pipe section Ø 16-18 mm minimum).  
 Dosing pump for rinsing product, flow rate managed by microprocessor.  
 Basket (catch all) 630 x 630 > **C63 & PA63**.  
 Basket (catch all) 830 x 830 > **C87 & PA87**.

### ► ONE-YEAR GUARANTEE

**For further information :**  
**Tél : +33 327 84 36 28**  
 Fax : +33 327 77 89 44

**contact@bodson-industrie.com**  
 Z.I. N° 1 - B.P. 50009  
 59360 LE CATEAU-CAMBRESIS - FRANCE

SASA INDUSTRIE GROUP

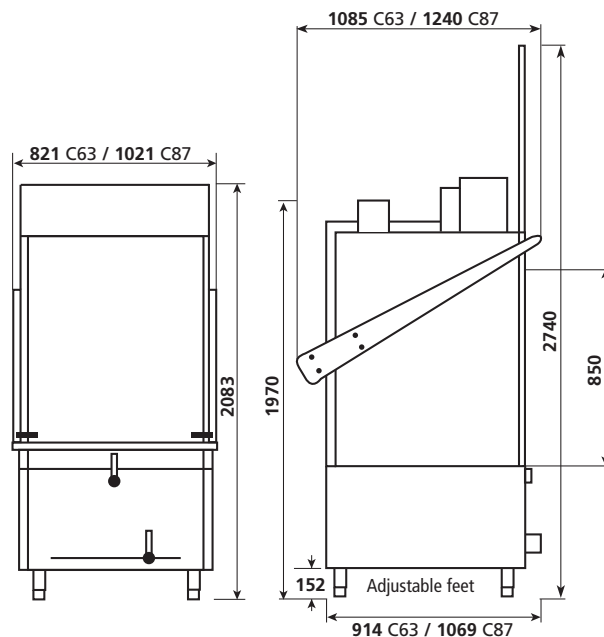

**C63**  
**C87**

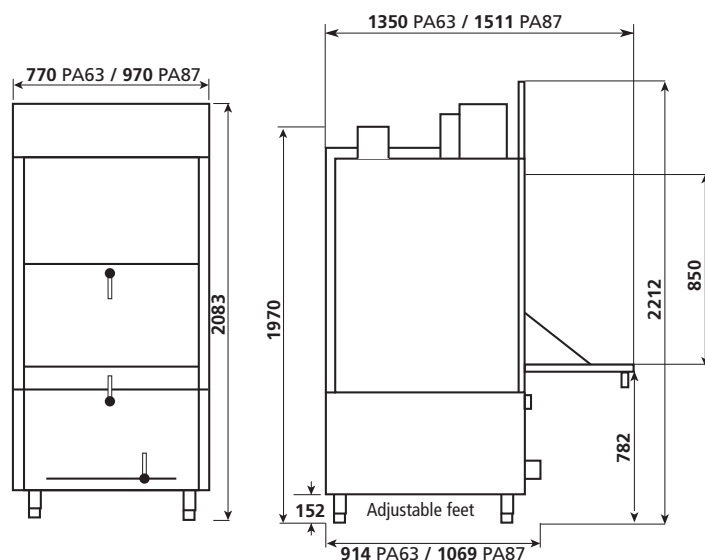

**PA63**  
**PA87**