

► **Fully automatic, easy to use, with a safety perimeter, the mixers-cookers**

- enable the cooking, mixing and cooling of products entering into culinary preparations (pasta, rice, vegetables, meat, fish, etc.)
- offer a wide range of options :
  - vacuum cooking,
  - drain trap,
  - bottom drainage, etc...
- They come in 3 models :  
**200 litres, 450 litres and 800 litres**
- are manufactured according to the standards and directives in force.



450 L

**SASA BODSON industrie :**

French manufacturer and designer, acknowledged by the entire profession, SASA Bodson develops **washing, cooking and vacuum packing** processes for the industry and food industry. With over 40 years of experience in high performance washing, the Company's key words are efficiency, reliability, sturdiness, savings and hygiene. Its highly effective after-sales service is ensured by our approved installers.

**The world of SASA BODSON Industrie ;**

a wide range of :

- **mixers cookers,**
- **cooking units,**
- **equipment washers,**
- **tunnels, rinsing, disinfecting,**
- **vacuum machines.**

**COOKING, MIXING AND COOLING  
in 200 - 450 - 800 L**



**Design and manufacture  
of machines tailored to a specific process.**

### ► TECHNICAL FEATURES

- Manufactured in stainless steel.
- Fully automatic and user-friendly :
  - 15-inch control touch screen
  - 20-program controller
- Cover opening and swivel of tank by hydraulic cylinder.
- Direct steam injection heating (double boiler cooking optional).
- Stirring pale with scraper.
- Stainless steel pneumatic cylinder lid flanging.
- Stainless steel PT 100 probe.
- Safety perimeter.

### ► OPTIONS

- Vacuum Packing.
- Load of the Europe container type.
- Cooling.
- Double-walled cooking.
- Drain trap.
- Bottom drainage valve.



450 L

Lift and unload your containers with ease "Euro" 200 liters.

- Silent OPERATION.
  - Easy to use.
  - Overflow height maximum 2.30 m
- For other specifications, contact us

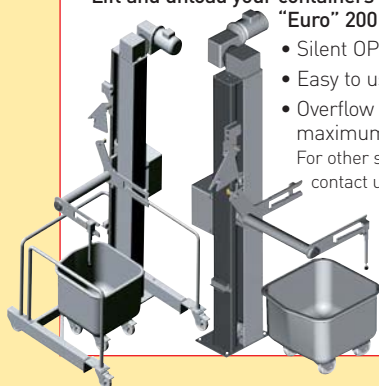

**For further information :**  
**Tél : +33 327 84 36 28**  
 Fax : +33 327 77 89 44

**contact@bodson-industrie.com**  
 Z.I. N° 1 - B.P. 50009  
 59360 LE CATEAU-CAMBRESIS - FRANCE

SASA INDUSTRIE GROUP

MODELS	200 L	450 L	800 L
Electrical power	4,1 kW	7 kW	8 kW
Heating temperature 2.5 bar	120°	120°	120°
Mixing speed	Variable from 2 to 20 rpm		
Useful capacity	200 liters	450 liters	800 liters
Overall dimensions WxDxHmm	1850 x 1300 x 2180	1931 x 1400 x 2250	2130 x 1730 x 2390

