

CARACTÉRISTIQUES

- ▶ **Robust** : stainless steel construction.
- ▶ **Silent OPERATION** : load driven by stainless steel chain via a gear motor.
- ▶ **Ease of use** : pushbutton control for ascent and descent with continuous action.
- ▶ **Maximum overflow height** :
 - Standard version : 2.3 m
 - For other heights, contact us.
- ▶ **Power** : 1,1 kW.
- ▶ **Tension** : three-phase 380 V 50 Hz, 24V control.
- ▶ **Options available** :
 - mobile trolley,
 - overflow pipe.

SASA BODSON industrie :

French manufacturer and designer, acknowledged by the entire profession, SASA Bodson develops washing, cooking and vacuum packing processes for the industry and food industry. With over 40 years of experience in high performance washing, the Company's key words are efficiency, reliability, sturdiness, savings and hygiene. Its highly effective after-sales service is ensured by our approved installers.

The world of SASA BODSON industrie ;

- a wide range of :
- mixers-cookers,
 - cooking units,
 - equipment washers,
 - tunnels, rinsing, disinfecting,
 - vacuum machines.

**LIFT AND LOAD YOUR
"EUROPE" CONTAINER
WASHERS IN AN INSTANT
200 LITRES**

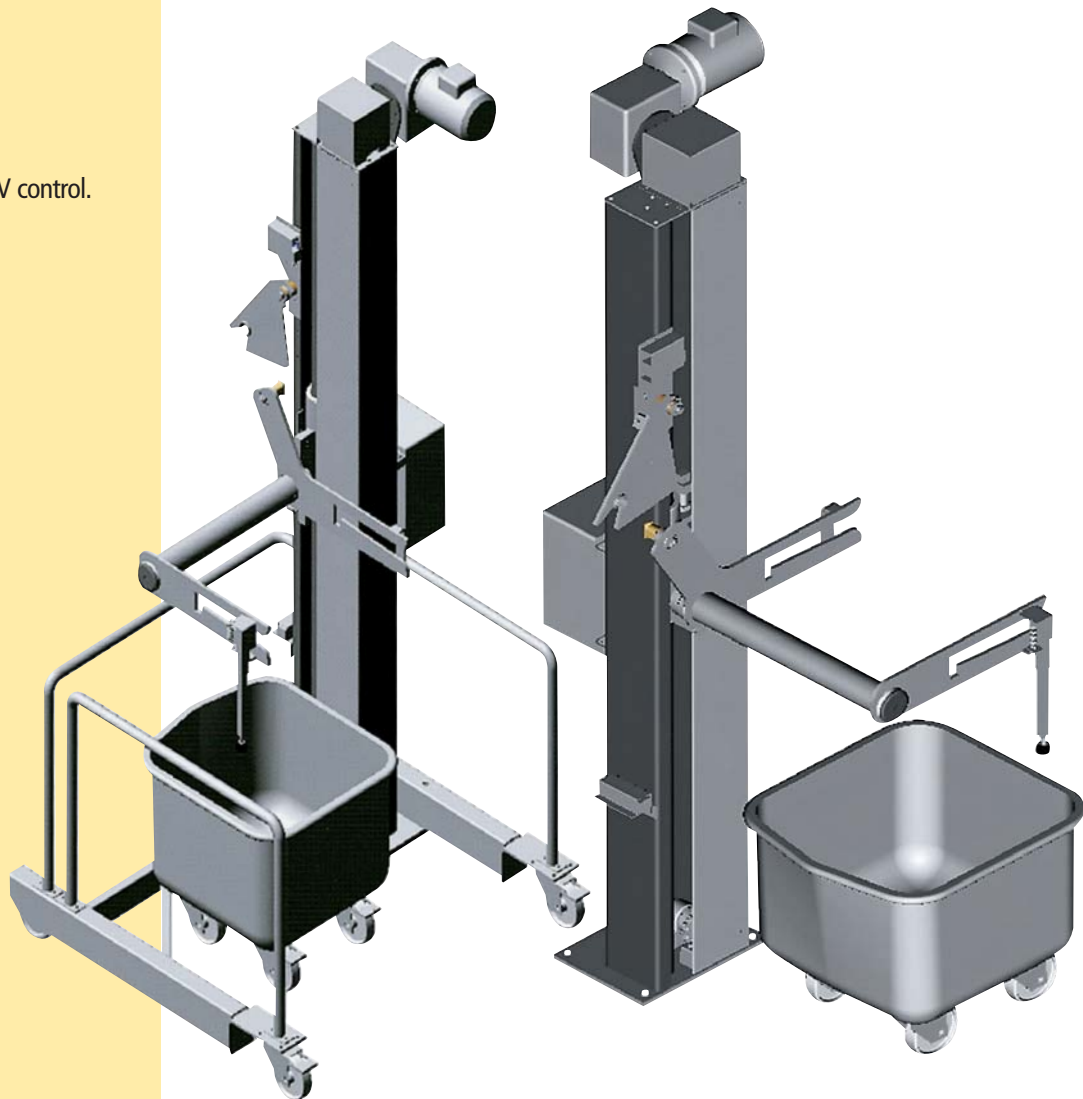

MODELS	Mobile	Fixed
Overall dimensions (mm)	1523 w x 1580 L x 3002 h	1273 w x 710 L x 2957 h

For further information :
Tél : +33 327 84 36 28
Fax : +33 327 77 89 44

contact@bodson-industrie.com
Z.I. N° 1 - B.P. 50009
59360 LE CATEAU-CAMBRESIS - FRANCE

SASA INDUSTRIE GROUP

**Design and manufacture
of machines tailored
to a specific process.**